

FRONT VIEW

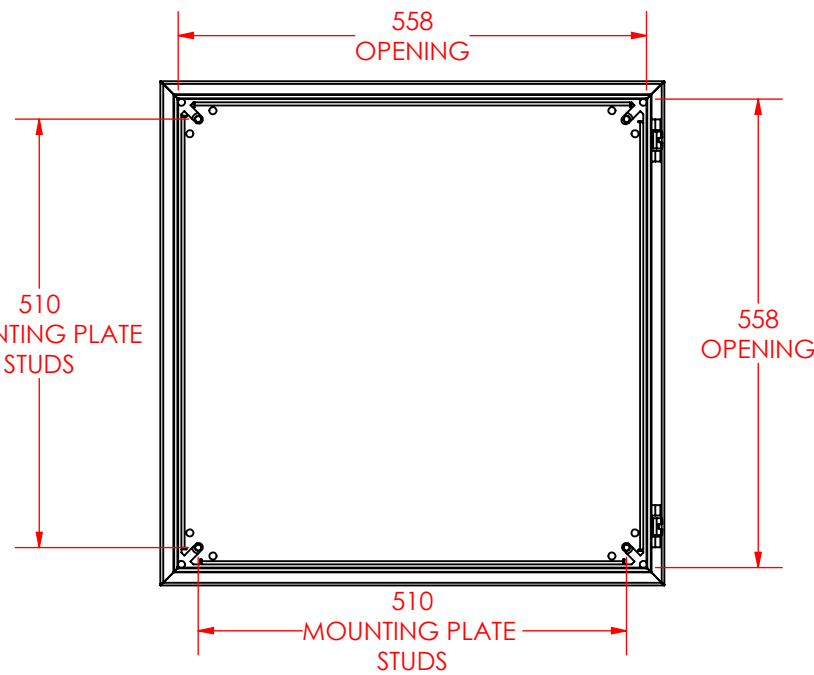

FRONT VIEW WITHOUT DOOR

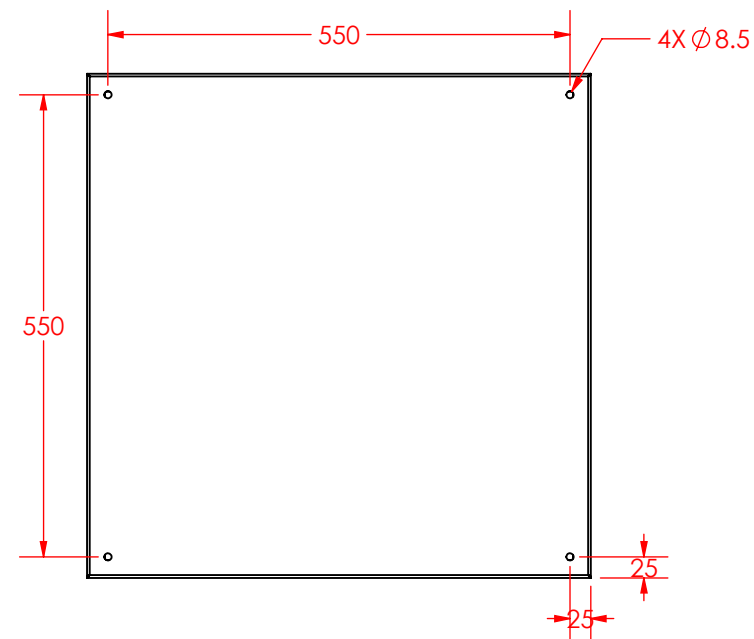

BACK VIEW

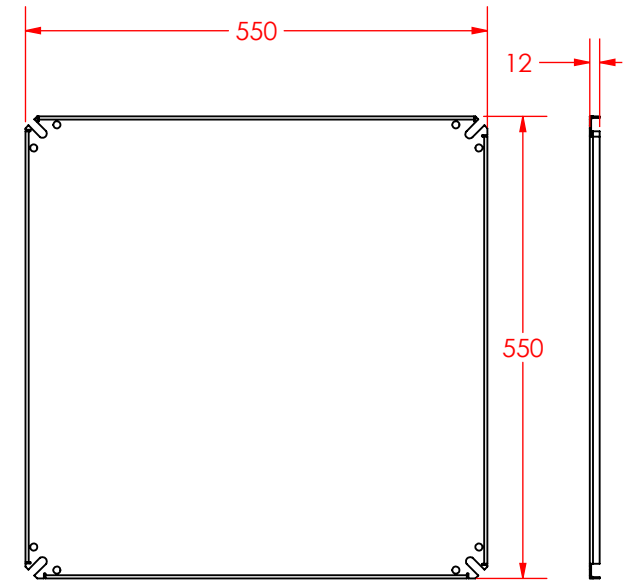

MOUNTING PLATE

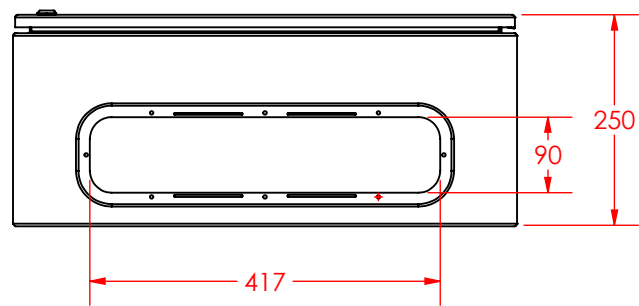

BOTTOM VIEW

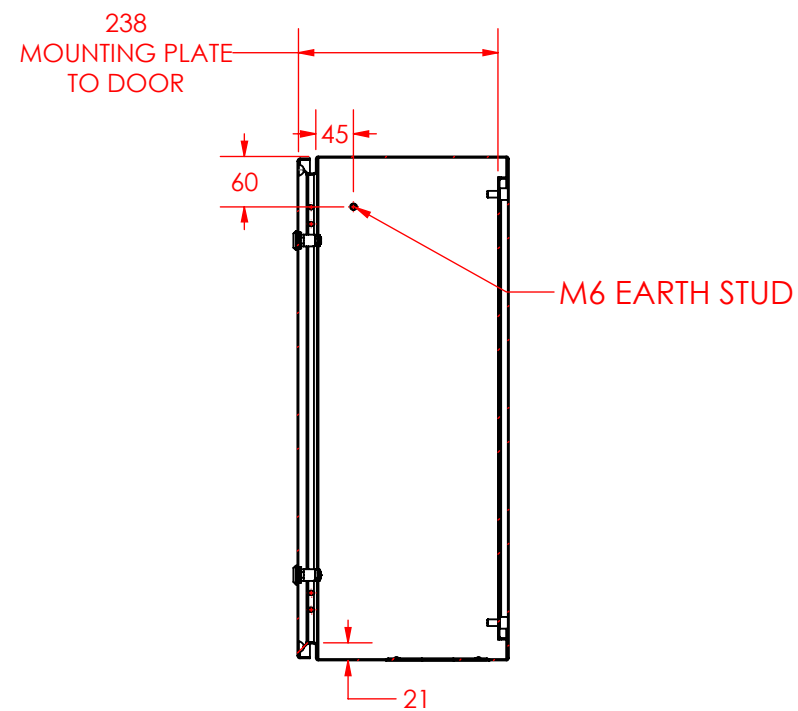

SECTION A-A  
SCALE 1 : 9

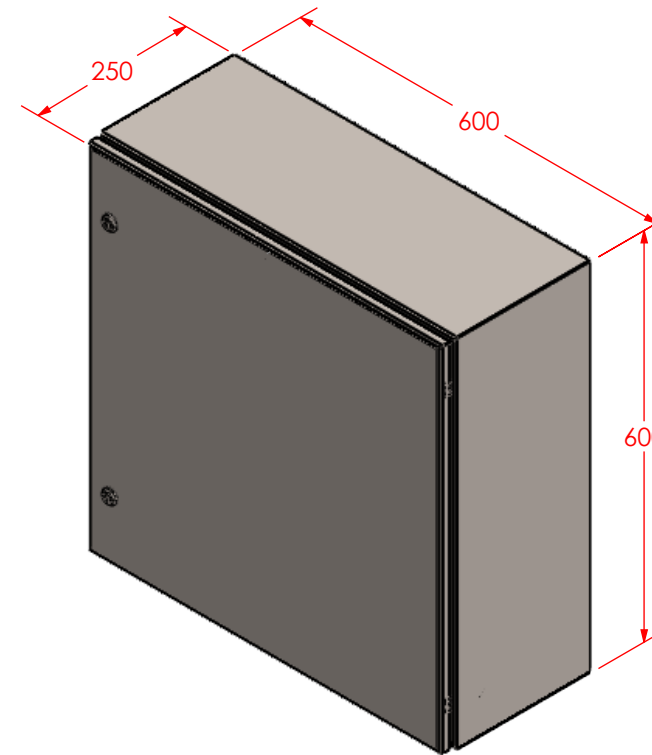

MATERIAL  
 BODY AND DOOR: 1.2MM 316SS  
 MOUNTING PLATE: 1.5MM GALVANISED STEEL

	DATE	01/04/2024	600x600x250 STAINLESS STEEL ENCLOSURE	
	DRAWN	E.B		
	REV	A		
ALL DIMENSIONS ARE IN MM	WEIGHT	19 KG	OSS606025	A3
MATERIAL: 316 STAINLESS STEEL		NOT TO SCALE	SHEET 10 OF 10	